

HSE-CONVEX SYSTEM

Horticultural Single-Ended Convex Lamp Premium Technology Reflector System

Growlite was the first horticulture lighting company to specifically design a compact reflector for reduced jacketed 1000W lamps.

The HSE-CONVEX precisely positions the outer envelope of the lamp slightly below the horizontal plane of the unit increasing the lamp's ability to evenly spread light across the plant canopy while the reflector controls light distribution.

Utilizing a mogul base socket, the HSE-CONVEX allows the reflector to operate a wide selection of wattages as well as HPS, CMH and Metal Halide lamps. Its small footprint, light weight and functionality make this a versatile product for many grow room applications.



FEATURES

- Fine hammertone reflector with 95% reflectance intensifies light with even coverage
- Convex technology precisely positions the lamp envelope just below the horizontal plane to provide more even light distribution
- Small, compact reflector design maximizes performance for lower wattage, reduced jacket lamps
- Universal ballast bracket allows for integral or remote ballast operation
- Exceptional housing quality ensures reliability and durability, minimizing down time due to maintenance and cleaning.
- Remote ballast mounting capability (15 feet)
- 825W, 750W and 600W Dimmable settings
- 1150W Overdrive setting
- External control capability (controls sold separately)
- Staggered start ignition
- LED display with status indicator

**AVAILABLE WHILE
 SUPPLIES LAST
 GLH-HSE & GLB-1000-DE-240/277
 (REFLECTOR and BALLAST ONLY)**

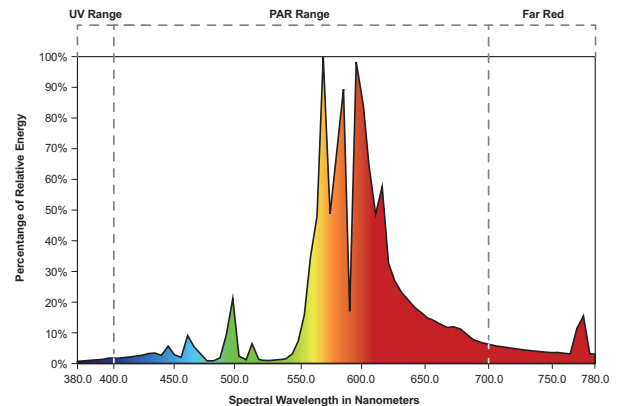

OTHER COMPATIBLE LAMPS AND BALLAST**

- 315W CMH SE lamp - [GLL-315-CSI](#)
- 600W HPS SE lamp - [GLL-600-HPS](#)
- 1000W MH SE lamp - [GLL-1000-MH](#)
- 600W MH SE lamp - [GLL-600-MH](#)
- 315W ballast 120/277VAC - [GLB-315-A-120/277](#)

ORDERING INFORMATION

Example: **GLH-HSE-1000-HPS-DA-240/277**

System/Configuration***	Description	
GLH-HSE-1000-HPS-DA-240/277*	HSE CONVEX SE Reflector, 1000W HPS DA lamp, 1000W DE ballast	
Individual Products	Description	Weight
GLH-HSE	HSE CONVEX SE Reflector	4.05 lbs (1.84kgs)
GLL-1000-HPS-DA	1000W HPS DA lamp	1.0 lbs (0.45kgs)
GLB-1000-DE-240/277	1000W DE ballast 240/277VAC	9.9 lbs (4.49kgs)

*Consult factory for additional accessories
 **Consult factory for optional system configurations
 ***System components ship in individual packaging

SPECIFICATIONS

REFLECTOR ([GLH-HSE](#))

- Fine hammertone reflector with 95% reflectance intensifies light with even coverage
- Convex technology precisely positions the lamp envelope just below the horizontal plane to provide more even light distribution
- Constructed of heavy-duty 22 gauge steel
- 12" 16AWG ballast connector for integral ballast mount
- 15' 16AWG lamp to ballast extension cord for remote ballast mount
- Mogul base socket allows the HSE-CONVEX to use commonly available lamps
- One (1) pair of V-hooks for mounting included
- Five Year Warranty (Terms and Conditions Apply)

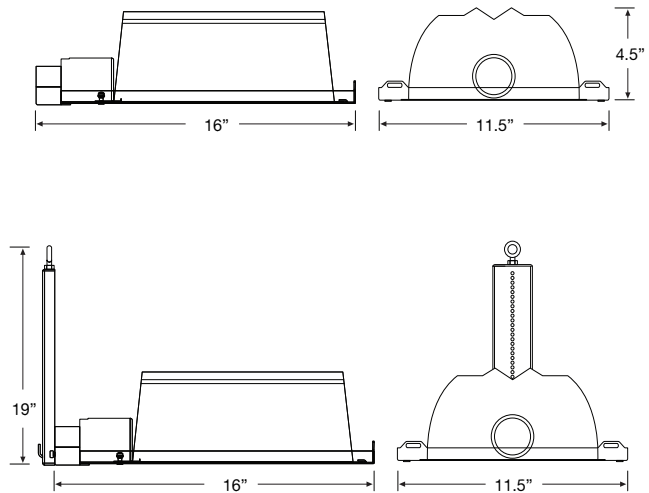

UNIVERSAL BALLAST BRACKET INCLUDED

1000W DE BALLAST ([GLB-1000-DE-240/277](#))

- Operates SE and DE 1000W lamps only
- 825W, 750W and 600W dimmable settings
- 1150W Overdrive setting
- External control capability (Controls sold separately)
- Staggered start ignition
- 240/277VAC Voltage sensing input
- 6' 240VAC Line cord with plug
- Standard S-Type lamp connector
- Three Year Warranty (Terms and Conditions Apply)

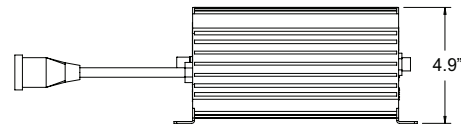
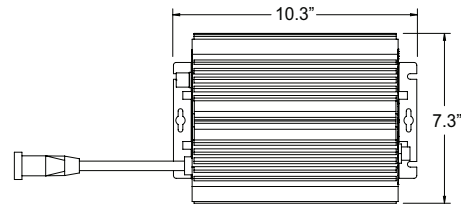

PERFORMANCE

- Rated Voltage: 240/277VAC
- Input Frequency: 50/60Hz
- Ambient operating temperature (TA): -20°C to +40°C (-4°F to +104°F)
- Total Harmonic Distortion (THD): <10%
- Current draw: 4.50A @ 240VAC, 3.80A @ 277VAC
- Inrush Current: 40A
- Operates > 100kHz

PROTECTIONS

- Short circuit
- Ignition failure
- Thermal Protection
- Over voltage
- Hot Re-strike
- Open circuit
- End of Lamp Life
- Soft-start
- Under-voltage

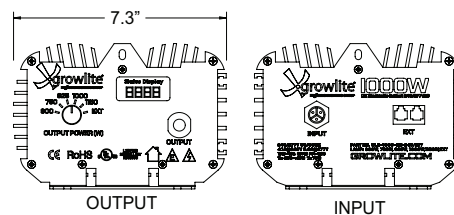

SPECIFICATIONS

1000W HPS DA LAMP ([GLL-1000-HPS-DA](#))

PHYSICAL DATA / REQUIREMENTS

- Lamp Wattage: 1000W
- PPF: 1,400 $\mu\text{mol/s}$
- Initial Lumens: 118,091
- Color Temperature: 2,000K
- Burning Position: UNIVERSAL
- Bulb Designation: BT37
- Fixture Rating: Open
- One Year Warranty (Terms and Conditions Apply)

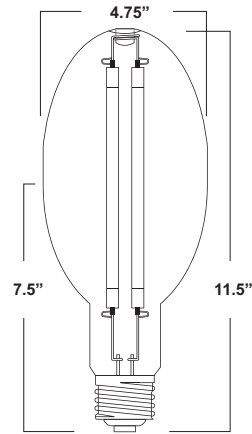

HSE-CONVEX SYSTEM

Horticultural Single-Ended Convex Lamp Premium Technology Reflector System

Growlite was the first horticulture lighting company to specifically design a compact reflector for reduced jacketed 1000W lamps.

The HSE-CONVEX precisely positions the outer envelope of the lamp slightly below the horizontal plane of the unit increasing the lamp's ability to evenly spread light across the plant canopy while the reflector controls light distribution.

Utilizing a mogul base socket, the HSE-CONVEX allows the reflector to operate a wide selection of wattages as well as HPS, CMH and Metal Halide lamps. Its small footprint, light weight and functionality make this a versatile product for many grow room applications.



FEATURES

- Fine hammertone reflector with 95% reflectance intensifies light with even coverage
- Convex technology precisely positions the lamp envelope just below the horizontal plane to provide more even light distribution
- Small, compact reflector design maximizes performance for lower wattage, reduced jacket lamps
- Universal ballast bracket allows for integral or remote ballast operation
- Exceptional housing quality ensures reliability and durability, minimizing down time due to maintenance and cleaning.
- Full-spectrum 315W CMH lamp with enhanced red spectral energy
- Operates all 315W CMH lamps
- Soft Start stabilizes start-up loads and extends lamp life and performance
- LED status displays voltage and wattage in normal operation
- 6' 120VAC Power cord provided
- 120/208/240/277VAC Voltage sensing input
- Standard S-Type lamp connector

AVAILABLE WHILE SUPPLIES LAST

**GLH-HSE & GLB-315-A-120/277
(REFLECTOR and BALLAST ONLY)**

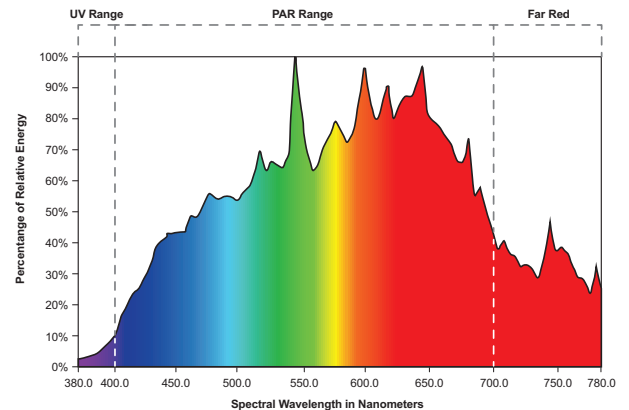

OTHER COMPATIBLE LAMPS AND BALLAST**

- 1000W HPS DA lamp - [GLL-1000-HPS-DA](#)
- 600W HPS SE lamp - [GLL-600-HPS](#)
- 1000W MH SE lamp - [GLL-1000-MH](#)
- 600W MH SE lamp - [GLL-600-MH](#)
- 1000W DE ballast 240/277VAC - [GLB-1000-DE-240/277](#)

ORDERING INFORMATION

Example: **GLH-HSE-315-CSI-120/277**

System/Configuration***	Description	
GLH-HSE-315-CSI-120/277*	HSE CONVEX SE Reflector, 315W CMH SE lamp, 315W ballast	
Individual Products	Description	Weight
GLH-HSE	HSE CONVEX SE Reflector	4.05 lbs (1.84kgs)
GLL-315-CSI	315W CMH SE lamp	1.0 lbs (0.45kgs)
GLB-315-A-120/277	315W ballast 120/277VAC	5.5 lbs (2.5kgs)

*Consult factory for additional accessories

**Consult factory for optional system configurations

***System components ship in individual packaging

SPECIFICATIONS

REFLECTOR ([GLH-HSE](#))

- Fine hammertone reflector with 95% reflectance intensifies light with even coverage
- Convex technology precisely positions the lamp envelope just below the horizontal plane to provide more even light distribution
- Constructed of heavy-duty 22 gauge steel
- 12" 16AWG ballast connector for integral ballast mount
- 15' 16AWG lamp to ballast extension cord for remote ballast mount
- Mogul base socket allows the HSE to use commonly available lamps
- One (1) pair of V-hooks for mounting included
- Five Year Warranty (Terms and Conditions Apply)

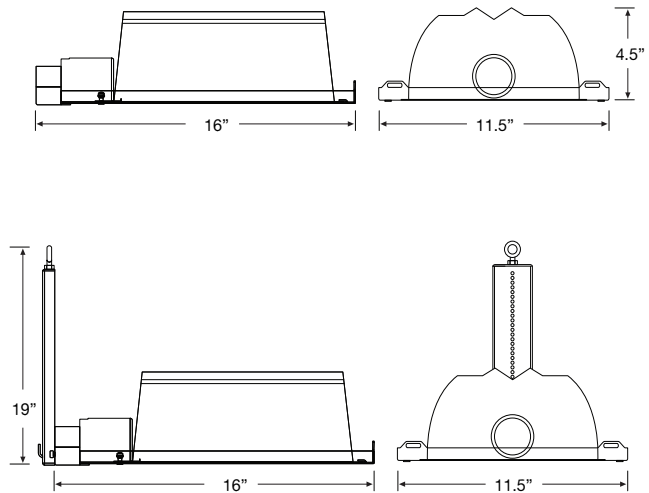

UNIVERSAL BALLAST BRACKET INCLUDED

315W BALLAST ([GLB-315-A-120/277](#))

- Operates all 315W CMH lamps
- Soft Start stabilizes start-up loads and extends lamp life and performance
- LED status displays voltage and wattage in normal operation
- 6' 120VAC Power cord provided
- 120/208/240/277VAC Voltage sensing input
- Standard S-Type lamp connector
- Three Year Warranty (Terms and Conditions Apply)

PERFORMANCE

- Rated Voltage: AC90-305VAC
- Input Frequency: 50/60Hz
- Ambient Operating Temperature (TA): -25°C to 50°C
- Crest Factor (CF): <1.5
- Power Factor (PF): ≥0.95
- Total Harmonic Distortion (THD): <20%
- Current Draw: 2.84A @ 120VAC, 1.42A @ 240V, 1.23A @ 277VAC

PROTECTIONS

- Short Circuit
- End of Lamp Life (EOL)
- Ignition Failure
- Over/Under Voltage
- Open Circuit
- Hot-Start
- Overheat

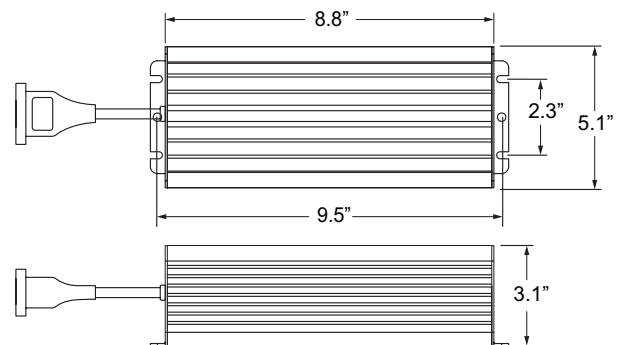

SPECIFICATIONS

315W CMH SE LAMP ([GLL-315-CSI](#))

PHYSICAL DATA / REQUIREMENTS

- Lamp Wattage: 315W
- PPF: 521 $\mu\text{mol/s}$
- Initial Lumens: 32,790
- Color Temperature: 4,000K
- Burning Position: UNIVERSAL
- Bulb Designation: ED37
- Fixture Rating: Open
- One Year Warranty (Terms and Conditions Apply)

